

T3 Class 2500

A105/LF2 ▶ 6170 PSI F316 ▶ 6000 PSI



Product features

- Forged Body and End Closures
- 3-Piece Threaded Construction
- In-line Weldable
- Dual Stem Seal
- Full or Reduced Port
- ASME B16.34
- NACE MR0175/ISO 15156
- Blow Out Proof Stem
- Anti-static Design
- NPT Ends to ASME B1.20.1
- SW Ends to ASME B16.11
- BW Ends to ASME B16.25
- Fire Safe to API 607
- Locking Handle
- API 598

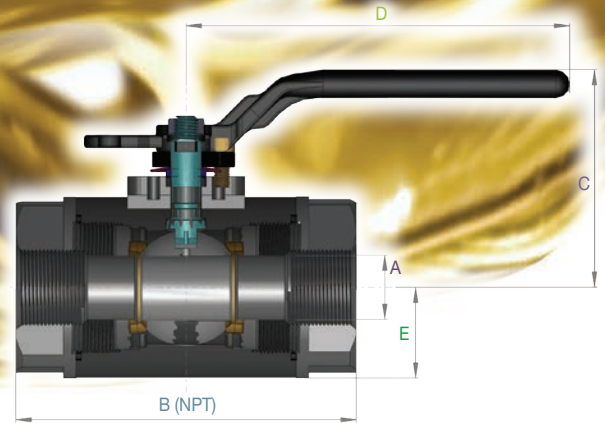

*T3 valve also available in Hammer Union end configuration

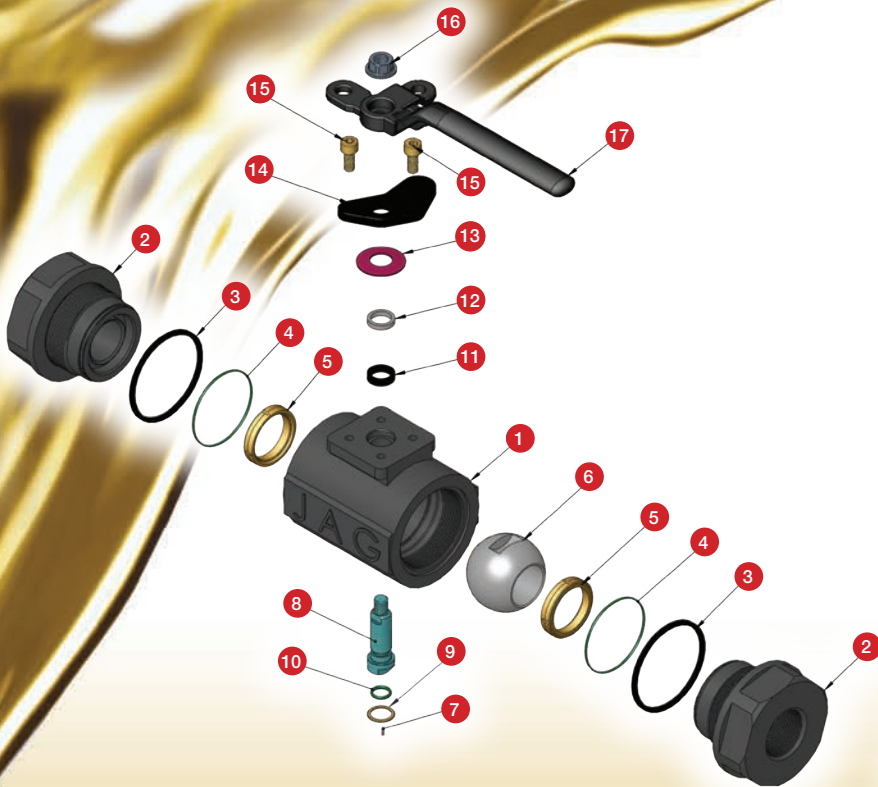
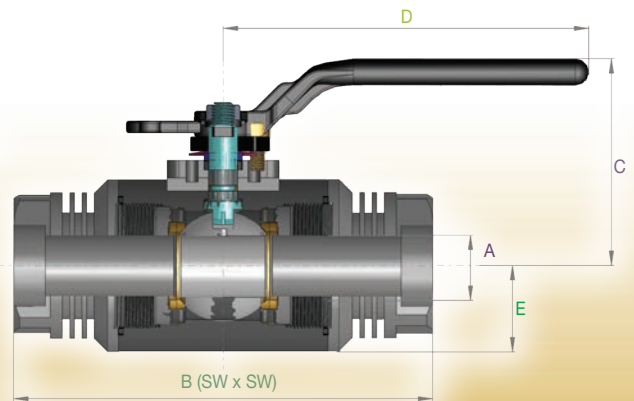
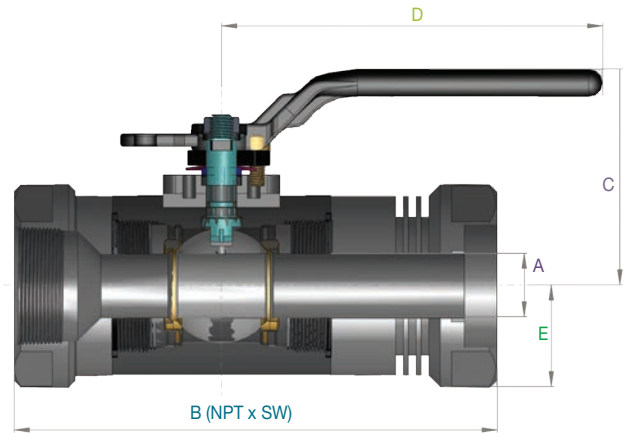

JAG Flocomponents Ltd.
4123 - 53rd Avenue NW
Edmonton, AB, CANADA T6B 3R5
Ph: 780.485.2333 • Fax: 780.485.2316
Email: info@jagflo.com • www.jagflo.com



JAG reserves the right to change design, materials or specifications without notice and free of obligation to furnish or install such changes on products previously sold.



T3 NPT/SW 2500 BOM						
No.	PART	QTY	Service			
			STANDARD	NACE	LOW TEMP NACE	STAINLESS STEEL
1	Body	1	A105	A105N	A350-LF2	A182-F316
2	End Cap	2	A105	A105N	A350-LF2	A479-316
3	Gasket	2	Graphite	Graphite	Graphite	Graphite
4	O-Ring	2	Viton	Viton	Viton	Teflon
5	Seat	2	PEEK	PEEK	PEEK	PEEK
6	Ball	1	17-4 ph	17-4 ph	17-4 ph	17-4 ph
7	Anti-Static Spring	1	304 SS	304 SS	304 SS	304 SS
8	Stem	1	AISI 4140	17-4 ph	17-4 ph	17-4 ph
9	Thrust Washer	1	PEEK	PEEK	PEEK	PEEK
10	O-Ring	1	Viton	Viton	Viton	Teflon
11	Stem Packing	1	Graphite	Graphite	Graphite	Graphite
12	Packing Follower	1	304 SS	304 SS	304 SS	304 SS
13	Belleville Washer	1	65Mn Spring Steel	65Mn Spring Steel	65Mn Spring Steel	304 SS
14	Gland Flange	1	WCB	WCB	WCB	304 SS
15	Gland Bolt	2	Stainless Steel	Stainless Steel	Stainless Steel	Stainless Steel
16	Handle Nut	1	Carbon Steel	Carbon Steel	Carbon Steel	304 SS
17	Handle	1	Carbon Steel	Carbon Steel	Carbon Steel	304 SS

T3 2500 DIMS																						
Size		Bore	A		B (NPT)		B (NPTxSW)		B (SWxSW)		C		D		E		Weight (NPT)		Weight (SW)		Weight (NPTxSW)	
in	mm	FP/ RP	in	mm	in	mm	in	mm	in	mm	in	mm	in	mm	in	mm	lbs.	kg.	lbs.	kg.	lbs.	kg.
1/4"	6.4	FP	0.50	12.7	3.86	98	4.44	112.8	5.00	127.0	3.26	82.8	6.5	165.1	0.87	22.1	3	1.4	4	1.8	4	1.8
3/8"	9.5	FP	0.50	12.7	3.86	98	4.44	112.8	5.00	127.0	3.26	82.8	6.5	165.1	0.87	22.1	3	1.4	4	1.8	3	1.4
1/2"	12.7	FP	0.50	12.7	4.37	111	4.69	119.1	5.00	127.0	3.26	82.8	6.5	165.1	0.87	22.1	3	1.4	4	1.8	4	1.8
3/4"	19.1	RP	0.50	12.7	4.37	111	5.57	141.4	6.75	172.0	3.26	82.8	6.5	165.1	0.94	23.9	4	1.8	5	2.3	4	1.8
		FP	0.75	19.0	4.25	108	5.50	139.7	6.75	172.0	3.67	93.2	8.5	214.9	1.18	30.0	6	2.7	7	3.1	7	3.1
1"	25.4	RP	0.75	19.0	5.24	133	6.00	152.4	6.75	172.0	3.67	93.2	8.5	214.9	1.18	30.0	6	2.7	8	3.6	7.2	3.25
		FP	1.00	25.4	5.39	137	6.07	154.1	6.75	172.0	3.93	99.8	8.5	214.9	1.40	35.6	9	4.1	11	5	10	4.5
1-1/4"	31.8	RP	1.00	25.4	6.43	163	7.46	190.0	8.50	217.0	3.93	99.8	8.5	215.9	1.40	35.6	11.3	5.1	14.3	6.5	13.2	6
		FP	1.50	38.0	6.30	160	7.38	188.0	8.50	217.0	5.30	134.6	10.0	254.0	2.02	51.3	19.5	8.8	24.2	11	22.2	10.1
1-1/2"	38.1	RP	1.00	25.4	6.43	163	7.46	190.0	8.50	217.0	3.93	99.8	8.5	215.9	1.40	35.6	11	5	14	6.36	13	5.9
		FP	1.50	38.0	6.30	160	7.38	188.0	8.50	217.0	5.30	134.6	10.0	254.0	2.02	51.3	19	8.6	24	10.9	22	10
2"	50.8	RP	1.50	38.0	7.40	188	7.96	202.5	8.50	217.0	5.30	134.6	10.0	254.0	2.02	51.3	23	10.4	25	11.3	24	10.9
		FP	2.00	50.8	6.26	159	8.05	204.5	9.85	250.0	6.30	160.0	12.4	315.0	2.61	66.3	33	15	44	20	38	17.2
3"	76.2	RP	2	50.8	10.28	261	12.76	324	11.52	292.5	7.48	190	16.15	410	3.65	70.5	54.5	24.75	66.7	30.3	59.3	26.9

Dimensions +/- 0.059 in (+/- 1.5mm)

