

Neway Full Opening Check Valve are designed in accordance with API 6D, it is available in class rating from 150~2500lb size 2"~48" With full opening design, this series of check valve can be capable for pig ball cleaning service. To prevent potential water hammer

damage caused by disc closing, a dashpot device can be assembled to control the disc closing time. The function of a check valve is to prevent reversal of flow automatically and promptly and this type of valves are usually supplemented by gate, ball or other valves.

Seat Ring is tight seal welded into valve body, however threaded seat ring can be also designed upon request

Body gasket:
For class 150~600lb is designed with spiral wound gasket with 316 inner ring Ring joint is used for class 900lb and above

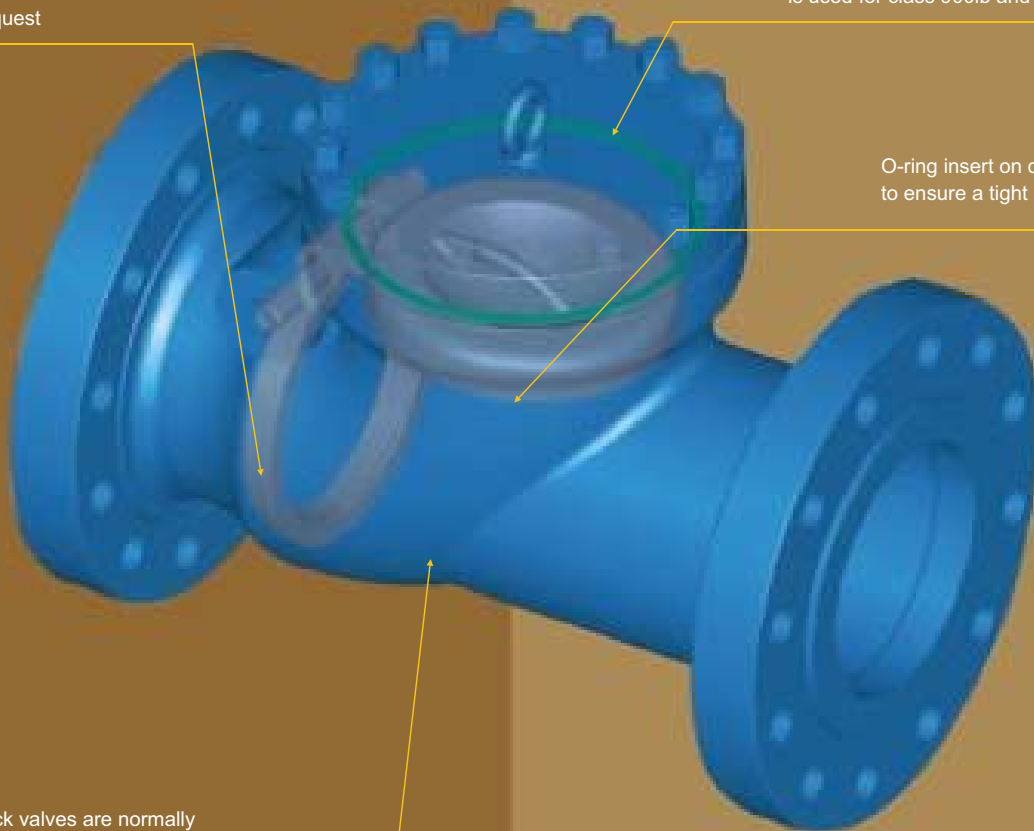

O-ring insert on disc sealing face to ensure a tight disc/seat seal

Drain Tapping
Neway swing check valves are normally provided with boss at location G, additional bosses can be provided upon request

- **Basic Design:** API 6D; ASME B16.34
- **Wall thickness:** ASME B16.34
- **End flange:** ASME B16.5, ASME B16.47
- **Butt weld ends:** ASME B16.25
- **Sour Service:** NACE MR 0175

This is atypical NEWAY series SF full opening check valve section drawing which is only for demonstrating of basic design features. The actual product design may be slightly different from this sample drawing due to its size and pressure class.

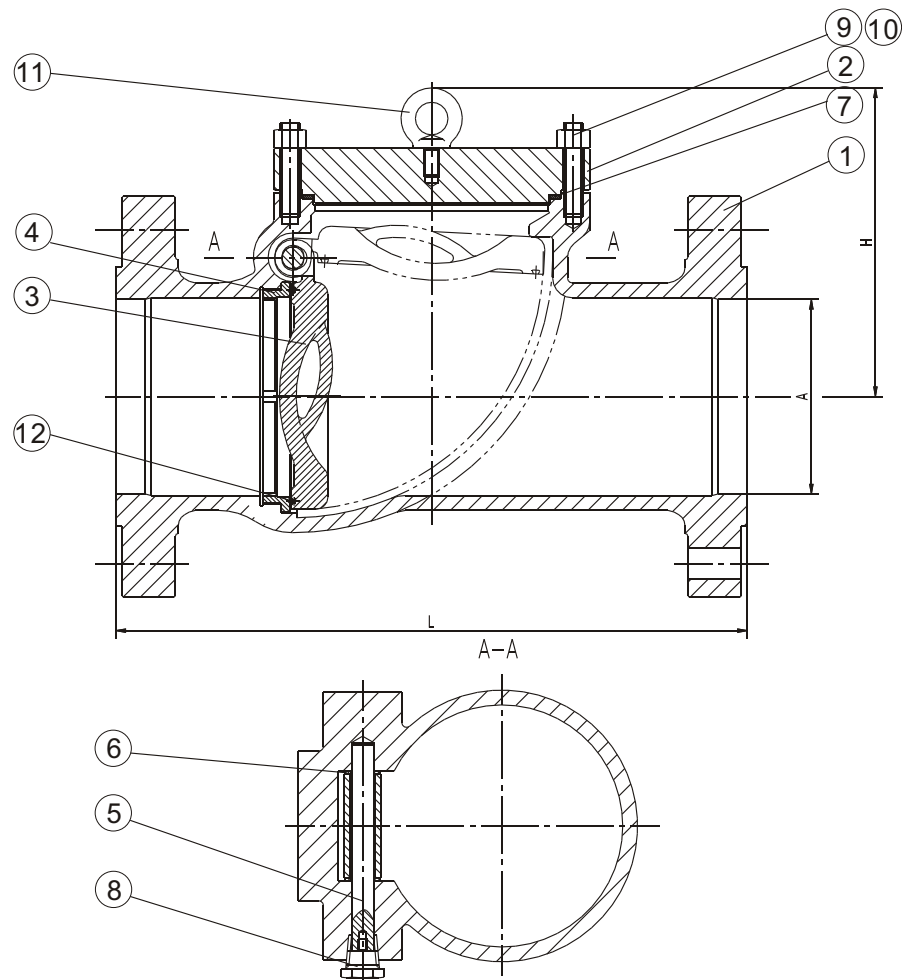

No.	Part	Standard	Sour Service	Low Temperature Service
1	BODY	ASTM A216-WCB	ASTM A216-WCB	ASTM A352-LCB
2	BONNET	ASTM A105	ASTM A105	ASTM A350-LF2
3	DISC	ASTM A216-WCB	ASTM A216-WCB	ASTM A352-LCB
4	SEAT RING	ASTM A105	ASTM A105	ASTM A350-LF2
5	HINGE PIN	ASTM A276-420	ASTM A276-420	ASTM A182-F316
6	WASHER	ASTM A276-420	ASTM A276-420	ASTM A182-F316
7	GASKET	316SS+GRAPHITE	316SS+GRAPHITE	316SS+GRAPHITE
8	PLUG	CARBON STEEL	CARBON STEEL	S.S.
9	STUD	ASTM A193-B7	ASTM A193-B7M	ASTM A320-L7M
10	NUT	ASTM A194-2H	ASTM A194-2HM	ASTM A194-7M
11	HOOK SCREW	CARBON STEEL	CARBON STEEL	CARBON STEEL
12	O-RING	NBR	NBR	NBR

jagflo.com

Dimensions

Series SF Full Opening Check Valve

Class 150LB

Size in	A	H	L mm	Weight RF Kg	Weight BW Kg
2	51	140	203	19	14
3	76	140	241	30	22
4	102	178	292	42	30
6	152.4	280	356	84	72
8	203	332	495	150	138
10	254	384	623.3	230	186
12	305	435	699	332	262
14	337	437	787	368	336
16	387	482	864	490	425
18	438	535	978	632	542
20	489	575	978	846	755
24	591	615	1205	1370	1190
26	635	684	1295	1450	1350
30	737	788	1524	2120	1830
36	876	929	1956	2980	2680
40	978	1090	1956	4870	4170
48	1168	1391	2540	7950	6730

Class 300LB

Size in	A	H	L mm	Weight RF Kg	Weight BW Kg
2	51	148	267	22	19
3	76	192	317.5	42	30
4	102	213	356	71	52
6	149.1	282	444	127	102
8	206.5	313	533.5	212	187
10	254	388	623	297	258
12	305	432	712	370	320
14	337	484	838	490	410
16	387	530	864	615	530
18	438	592	978	735	682
20	489	638	1016	980	790
24	591	720	1346	1815	1605
26	635	765	1346	2115	2005
30	737	868	1594	2460	2130
36	876	1020	2083	4730	4100
40	978	1180	2096	6780	5930
48	1168	2540	2540	13900	12100

Class 600LB

Size in	A	H	L mm	Weight RF Kg	Weight BW Kg
2	51	157	292	36	28
3	76	190	356	61	50
4	102	220	432	116	90
6	149	320.5	559	217	182
8	203	338.5	660.4	420	360
10	254	421	788	570	460
12	305	473	839	788	665
14	337	532	889	1020	865
16	387	642.5	990.6	1440	1200
18	438	668	1092	1695	1430
20	489	721	1194	2600	2230
24	591	803	1397	3600	3085
26	639	1026	1448	4715	4310
30	737	879	1651	5880	5420
36	876	957	2083	10450	9600
40	978	1112	2096	15400	14200

Class 900LB

Size in	A	H	L mm	Weight RF Kg	Weight BW Kg
3	76	169	384	82	68
4	102	202	460	160	135
6	152	388	613	272	215
8	203.2	415	740	548	446
10	254	458	839	944	840
12	305	504	966	1560	1370
14	324	571	1029	1660	1440
16	387	661	1130	2060	1780
18	425	708	1219	3020	2340
20	473	772	1321	3750	2900
24	572	897	1549	5400	4210

Class 1500LB

Size in	A	H	L mm	Weight RF Kg	Weight BW Kg
2	51	184	368	76	62
3	76	250	470	128	105
4	102	295	546	230	205
6	146	342	711	506	456
8	194	395	832	942	843
10	241	452	991	1750	1500
12	289	513	1130	2350	2020
14	314	567	1257	2950	2400
16	362	623	1384	3600	3015
18	407	688	1537	5500	4680
20	457	742	1664	6800	5600
24	534	862	1943	10150	8150

Class 2500LB

Size in	A	H	L mm	Weight RF Kg	Weight BW Kg
2	44	272	451	145	110
3	64	310	578	260	185
4	89	386	673	480	430
6	133	435	914	1020	830
8	181	498	1022	1700	1280
10	225	572	1270	3110	2410
12	267	689	1422	3700	2600

jagflo.com